

**PLAN VIEW**

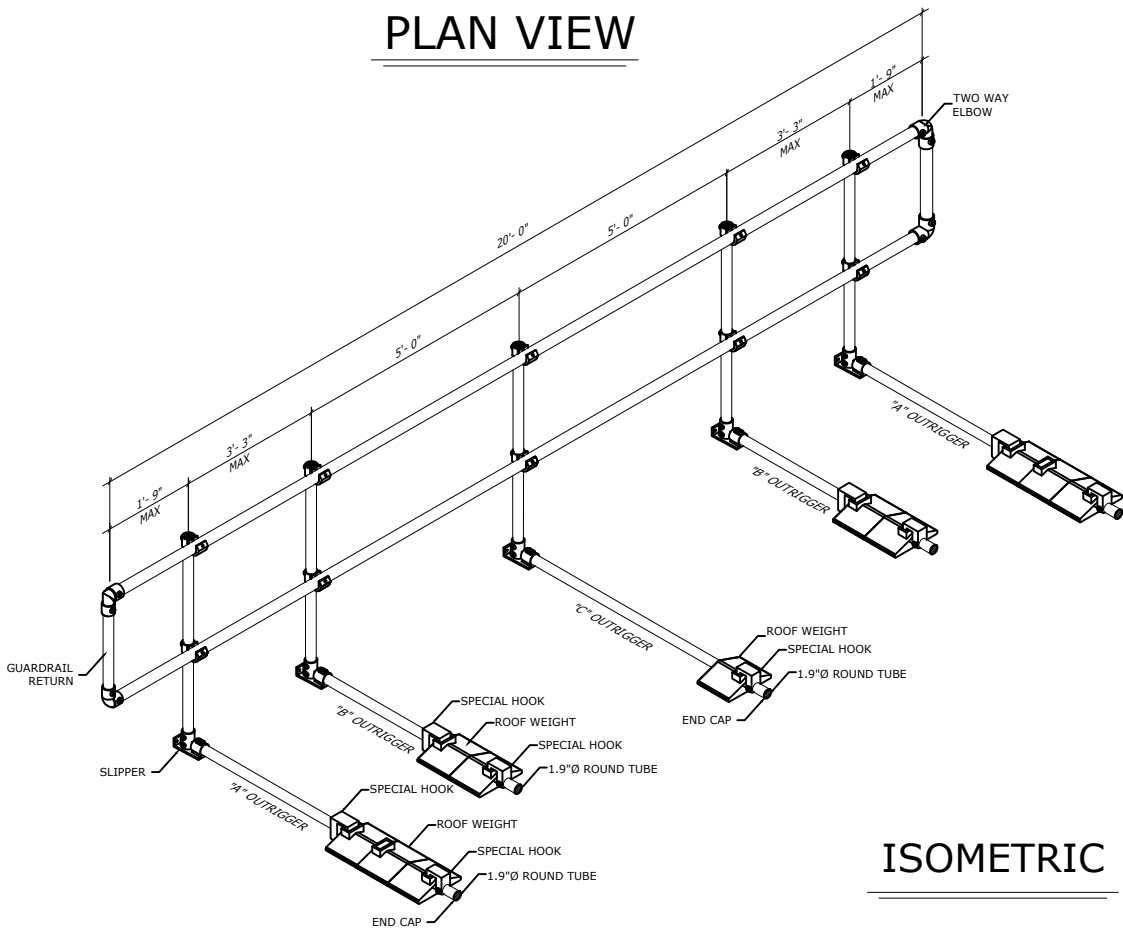

**ISOMETRIC**



SHEET TITLE:  
 SYSTEM: DYNAROUND RG ROOFGUARD  
 LAYOUT: 20' STRAIGHT RUN  
 POST SPACING: STD.  
 RETURN CONDITION: N/A

SCALE:  
 NTS  
 DRAWING No.:  
 DWG NO. 24